

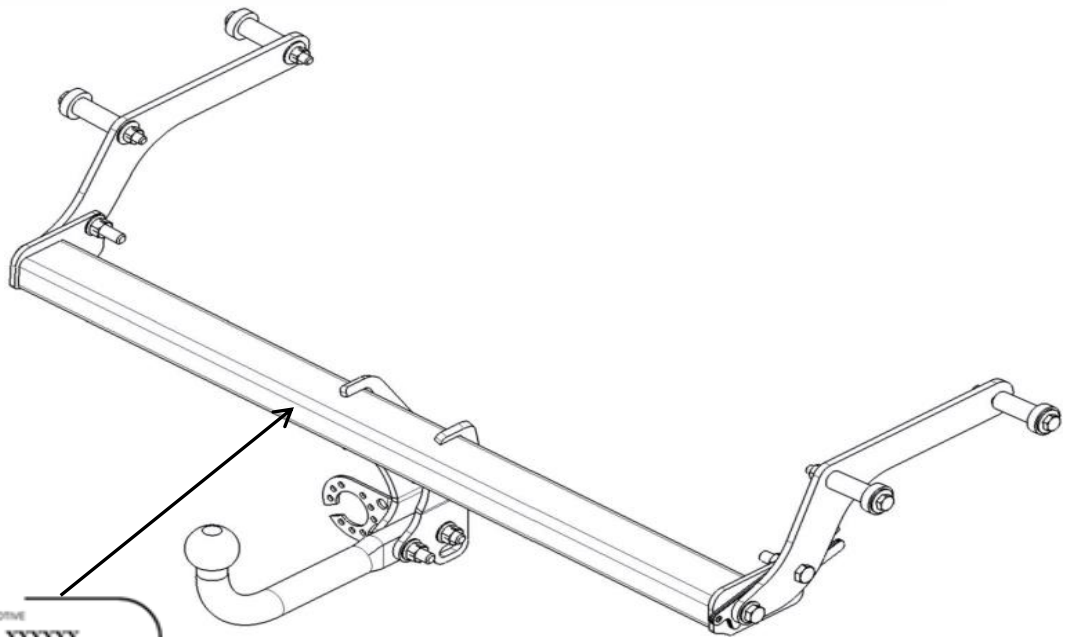

westfalia
AUTOMOTIVE

- D** **Anhängevorrichtung** Montage- und Betriebsanleitung, Originalbetriebsanleitung
- CZ** **Závěsné zařízení** Montážní a provozní návod
- DK** **Anhængertræk** Montage- og driftsvejledning
- E** **Enganche** Instrucciones de montaje y de servicio
- F** **Attelage** Notice de montage et d'utilisation
- FIN** **Perävaunun vetolaite** Asennus- ja käyttöohjeet
- GB** **Tow bar** Installation and Operating Instructions
- GR** **Διάταξη ζεύξης** Οδηγίες συναρμολόγησης και λειτουργίας
- H** **Vonóhorog** Beszerelési utasítás
- I** **Gancio di traino** Istruzioni di montaggio e per l'uso
- N** **Tilhengerfeste** Monterings- og bruksanvisning
- NL** **Trekhaak** Montage- en gebruikshandleiding
- PL** **Hak holowniczy** Instrukcja montażu i eksploatacji
- RUS** **Фаркоп** Инструкция по монтажу и эксплуатации
- S** **Dragkrok** Monterings- och bruksanvisning



siarr WESTFALIA AUTOMOTIVE	
CLASS : A 50 X	XXXXXX
N° Homologation ECER55	
e24	55R-01 0445
D	8,75 KN
S	75 Kg
TYPE	
SI 253	Réf. 316468600001
Made in FRANCE	

316 468 600 001

DACIA DUSTER 12/2017 ->

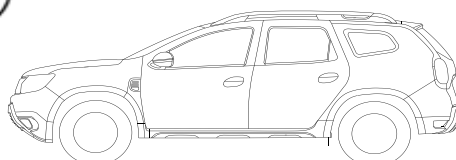

SR***
HS***

SIARR - WESTFALIA
Rue du Général de Gaulle
76810 LUNERAY
FRANCE

316 468 600 001

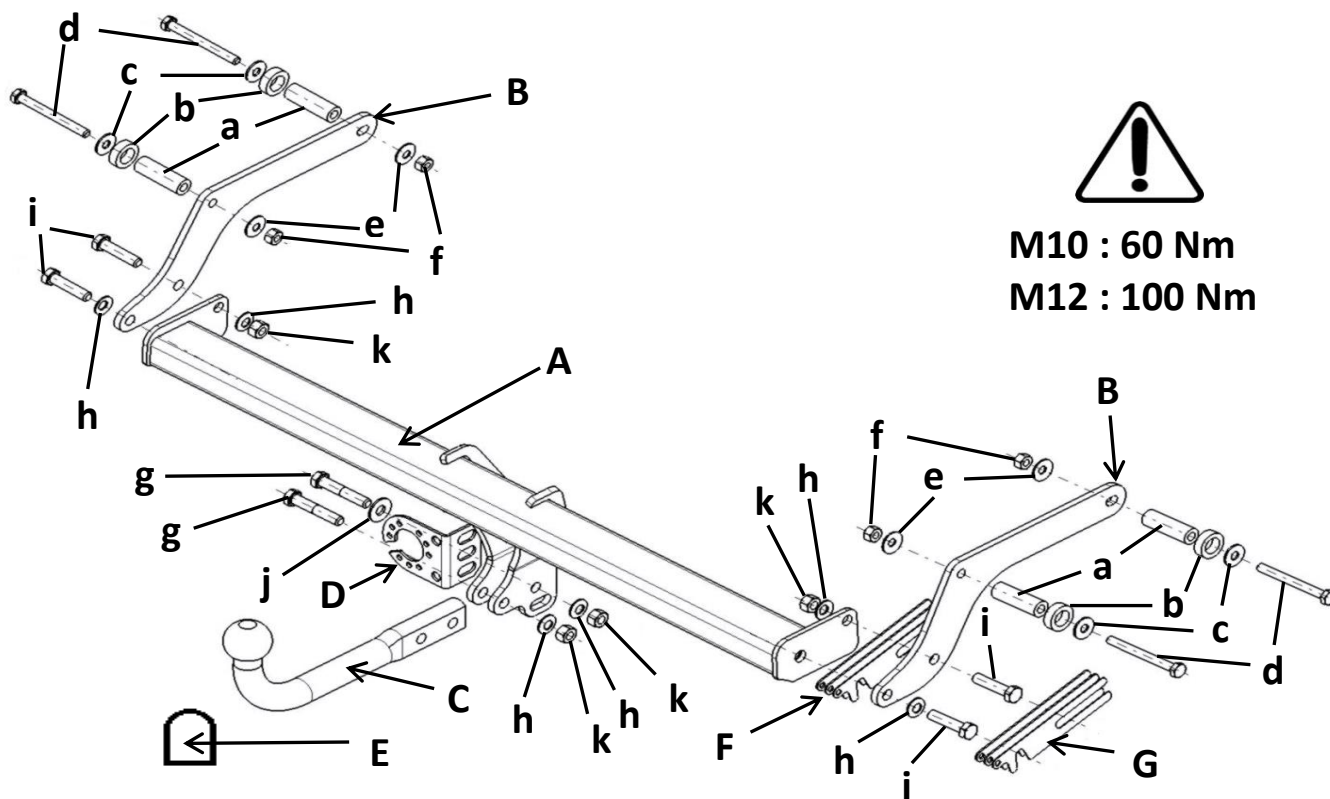

316 468 600 001

- | | |
|---|---|
| <p>A : 1</p> <p>B : 2</p> <p>C : 1</p> <p>D : 1</p> <p>E : 1</p> <p>F : 2 (1 mm)</p> <p>G : 4 (2 mm)</p> | <p>a : 4 x Ø 10,5/20 L = 61mm</p> <p>b : 4 x Ø 32 L = 20mm</p> <p>c : 4 x L 10,5/27 x 2</p> <p>d : 4 x HM 10x 95 cl 10.9 - 60 Nm</p> <p>e : 4 x CS 10</p> <p>f : 4 x M10 cl 10</p> <p>g : 2 x HM12 x 65 cl 10.9 - 100 Nm</p> <p>h : 6 x CS 12</p> <p>i : 4 x HM 12 x 45 Cl 10.9 - 100 Nm</p> <p>j : 1 L 12,5/30 x 3</p> <p>k : 4 x M12 cl 10</p> |
|---|---|

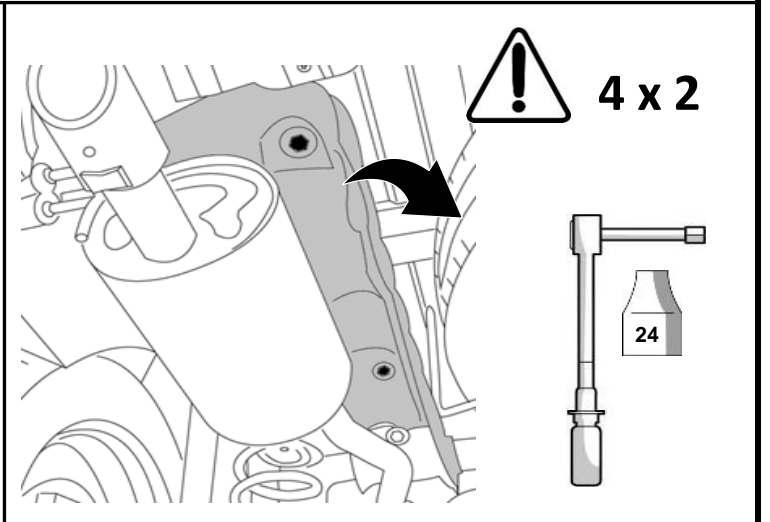
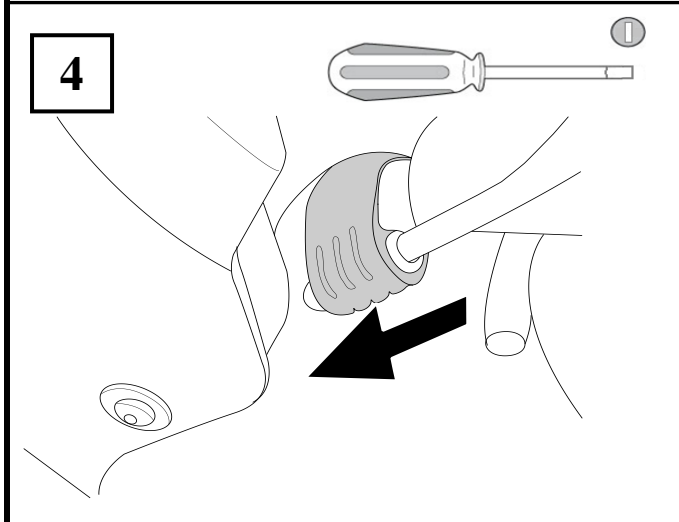
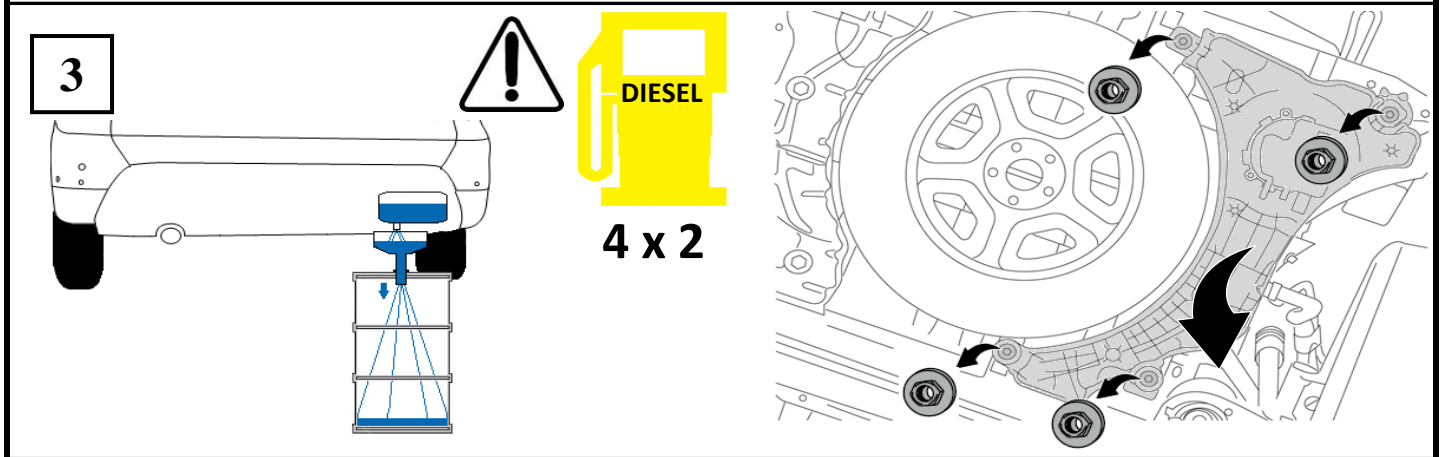
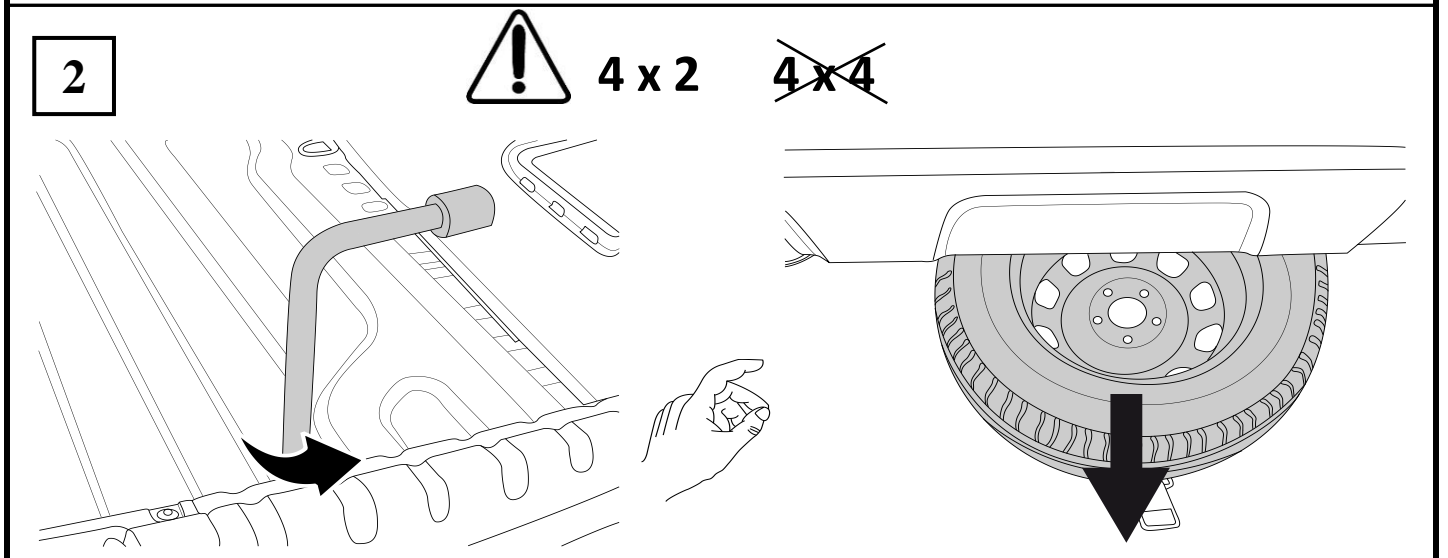
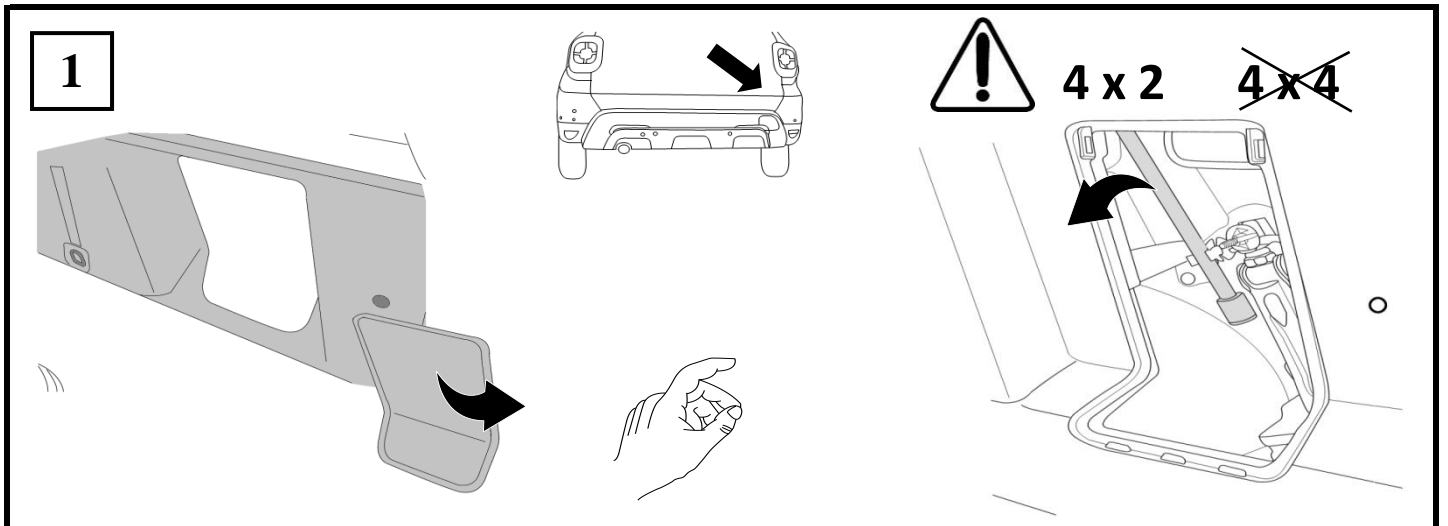

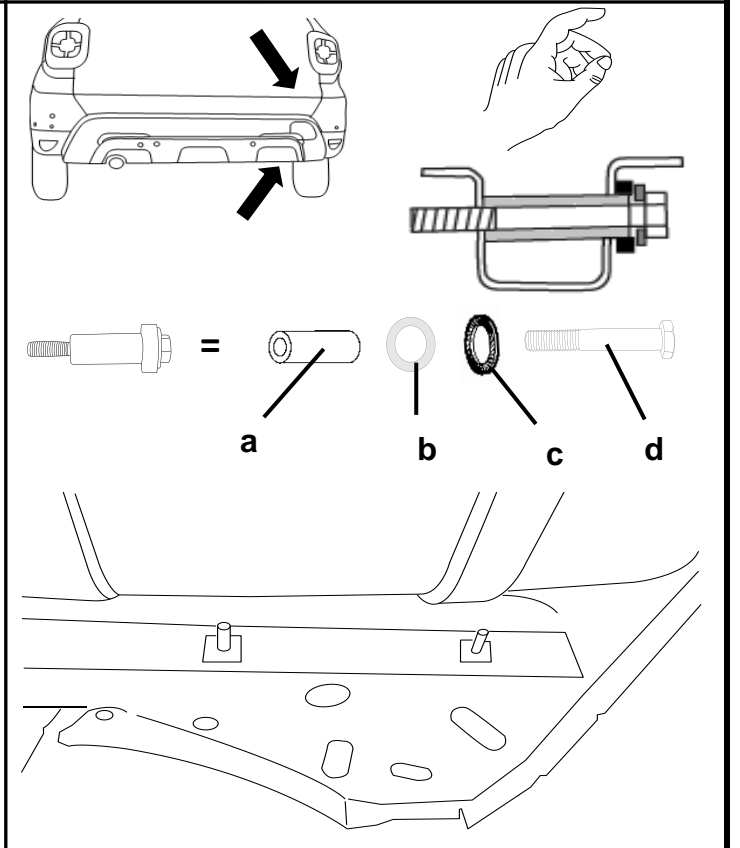
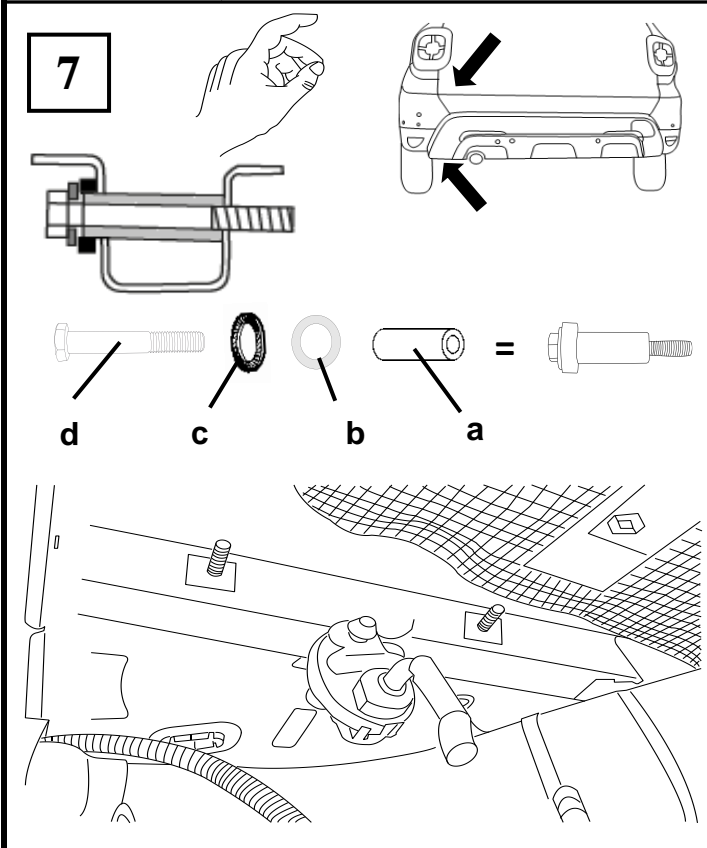
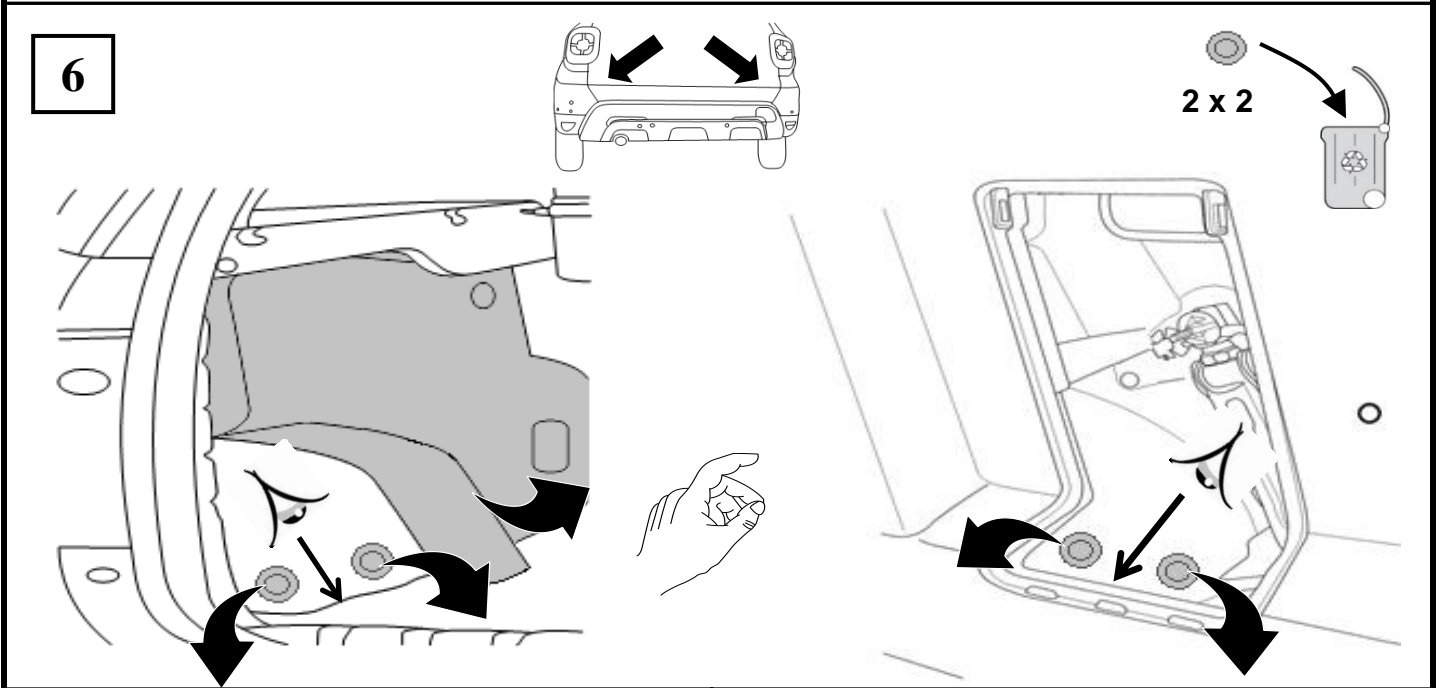
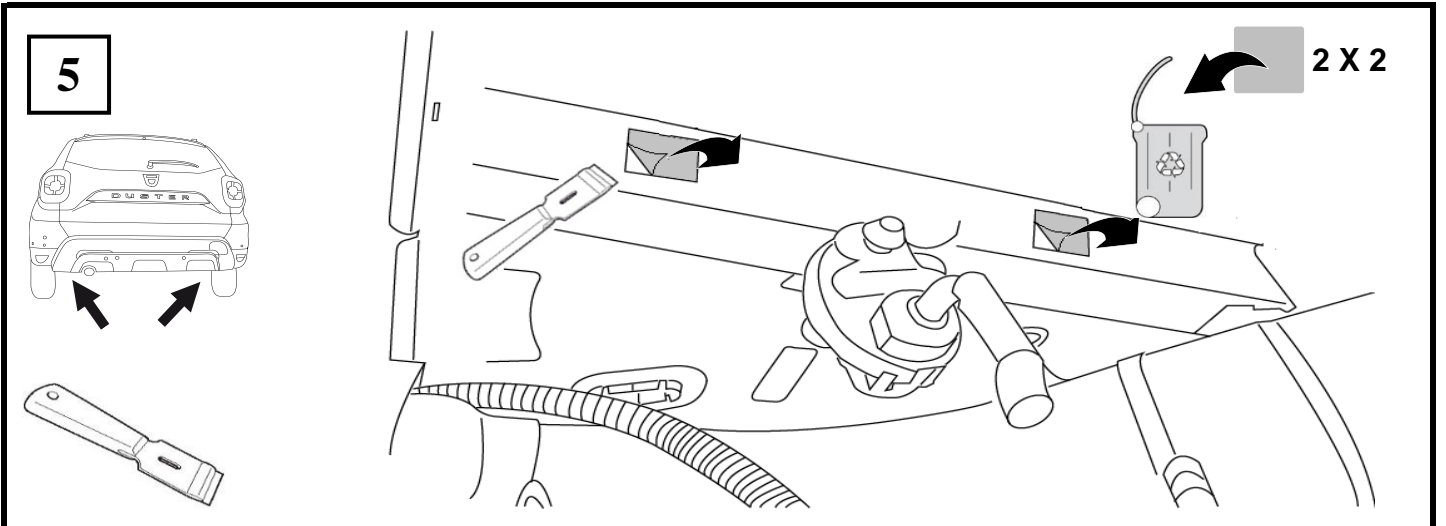

8

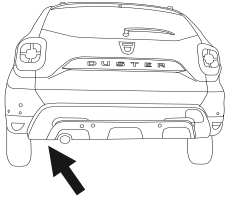

abcdef

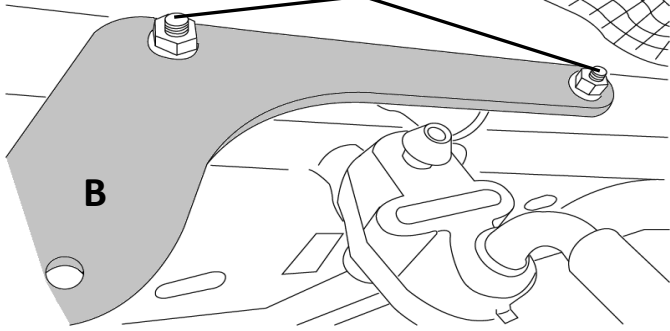

16 - 17



M10 - 60 Nm

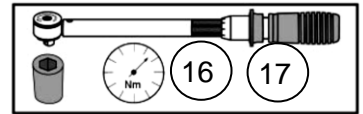

9

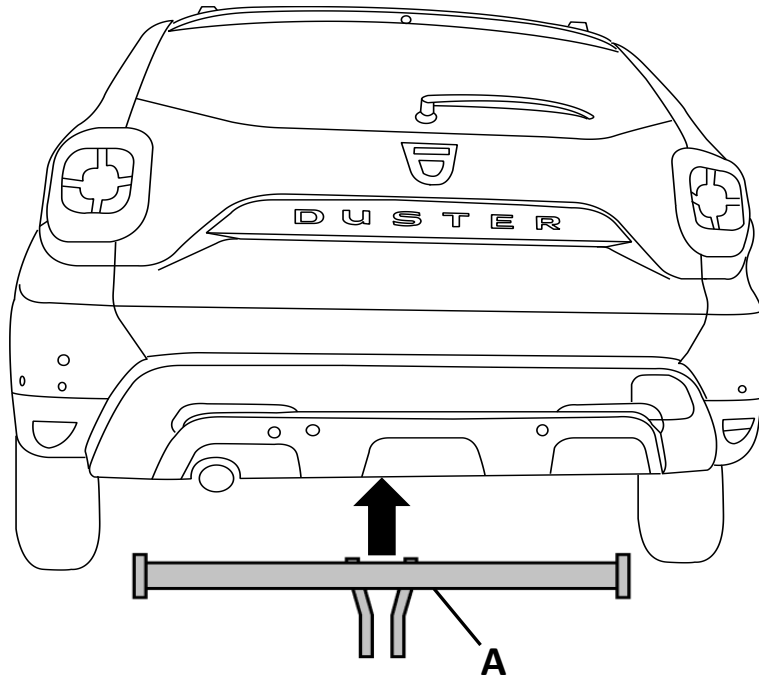

A

10

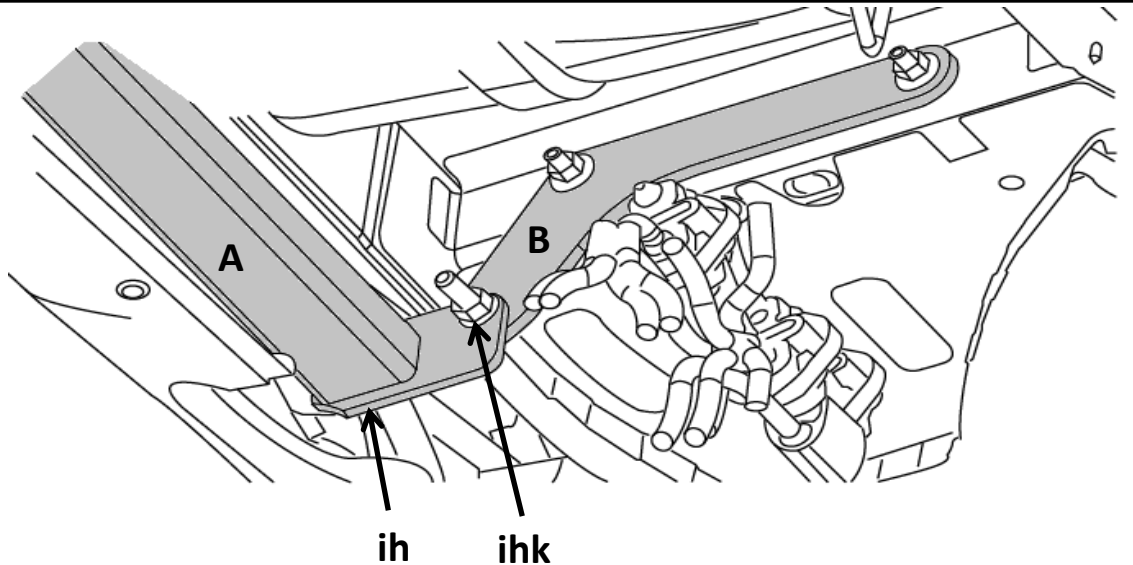
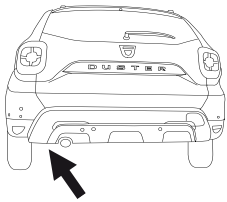

ih

ihk

11

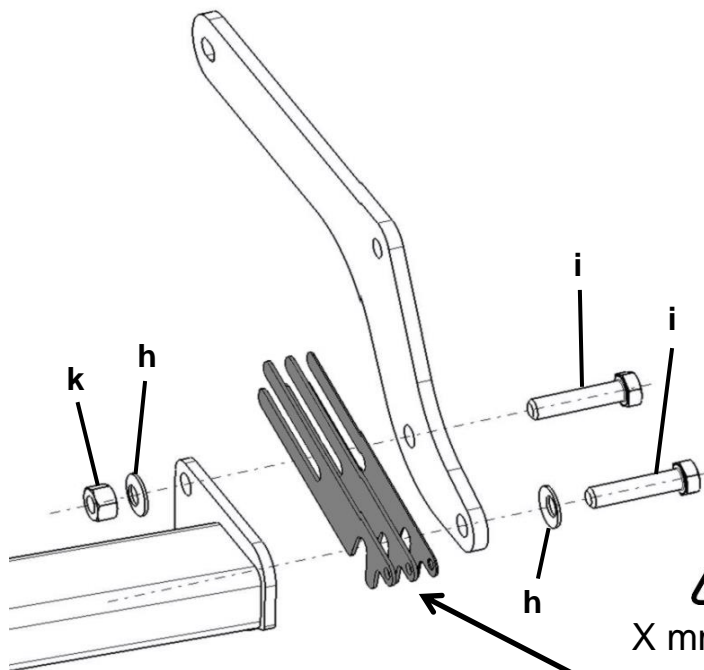
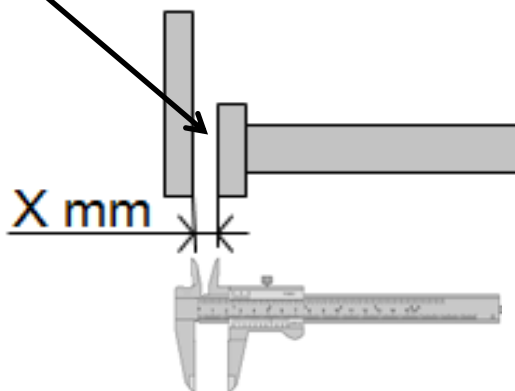
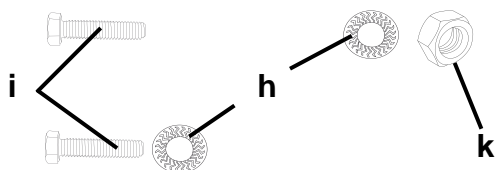
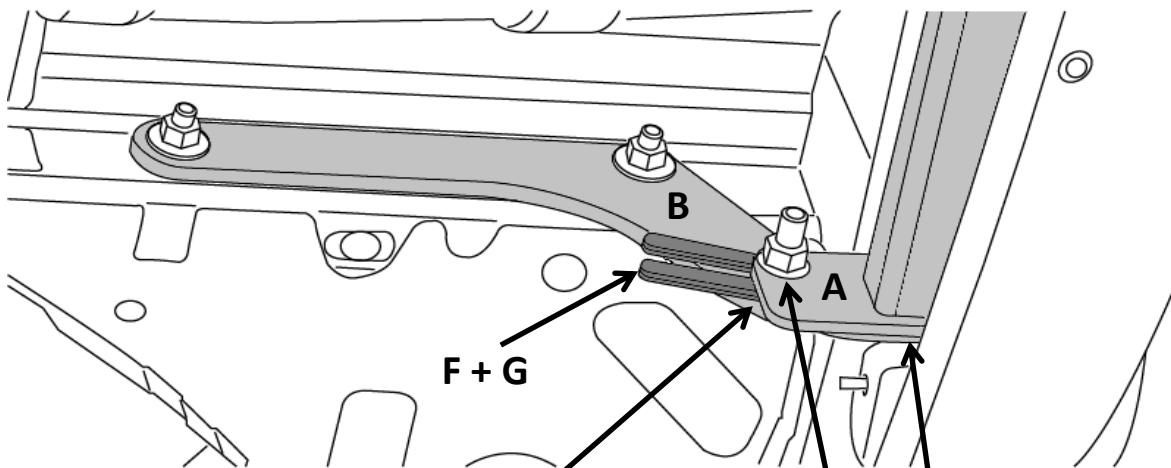
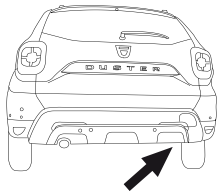

1 mm (x2)

2 mm (x4)



X mm = Y mm

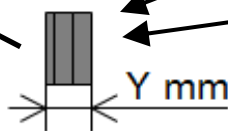
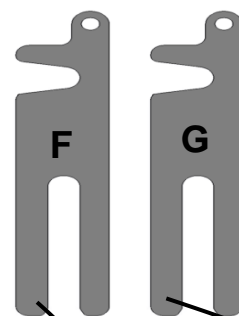

12₂

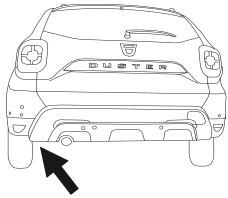

M12 - 100 Nm

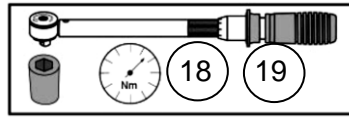
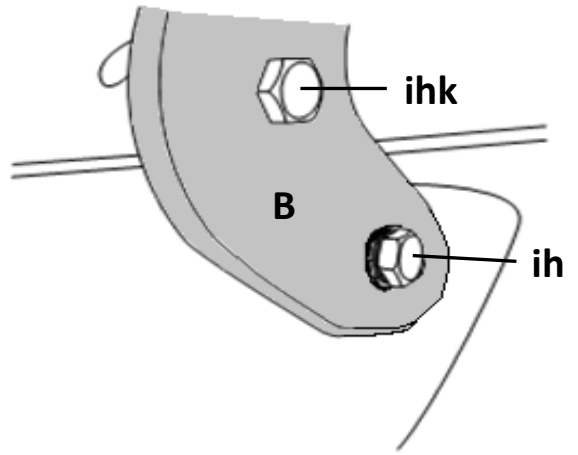

13

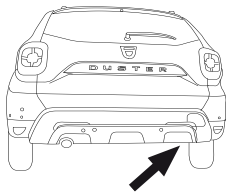

M12 - 100 Nm

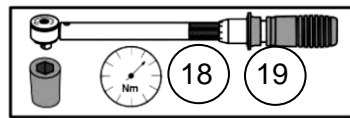
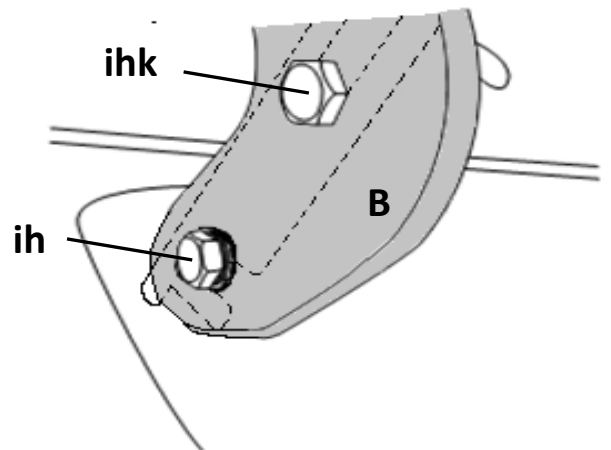

14

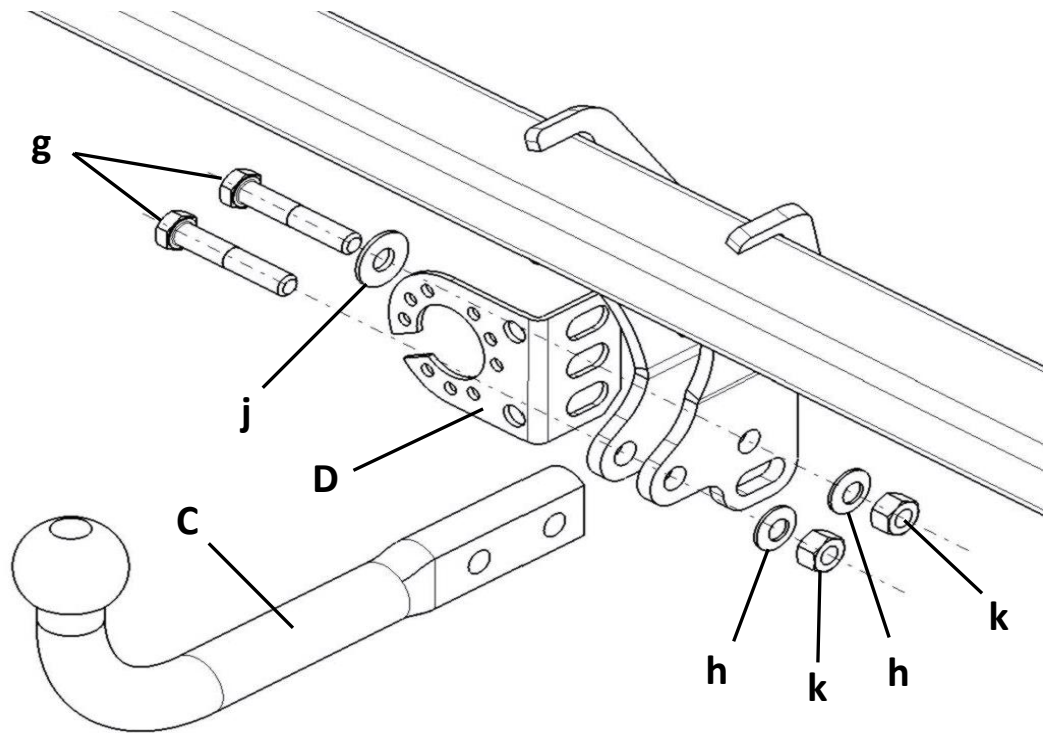

M12 CI 10.9 100 Nm

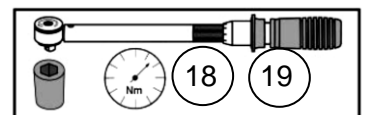

15₂



4 x 2

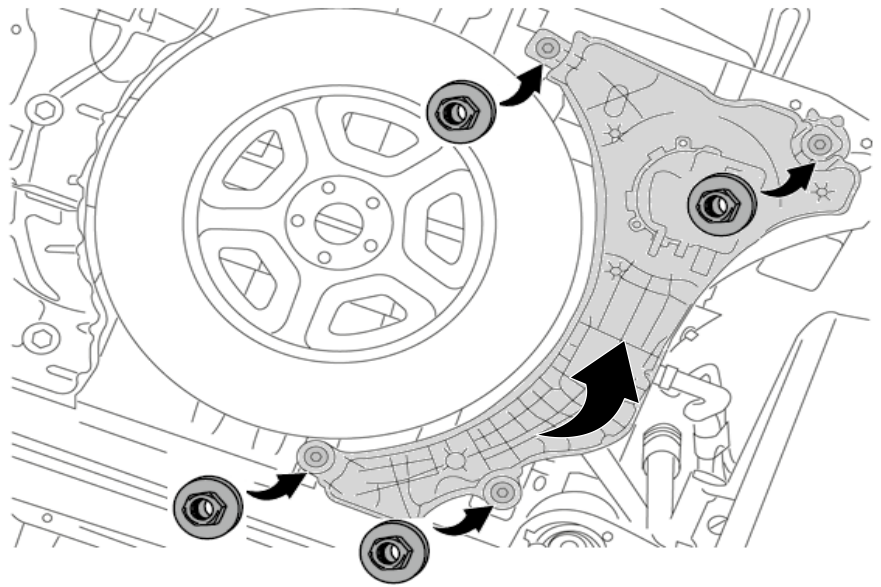

16



4 x 2

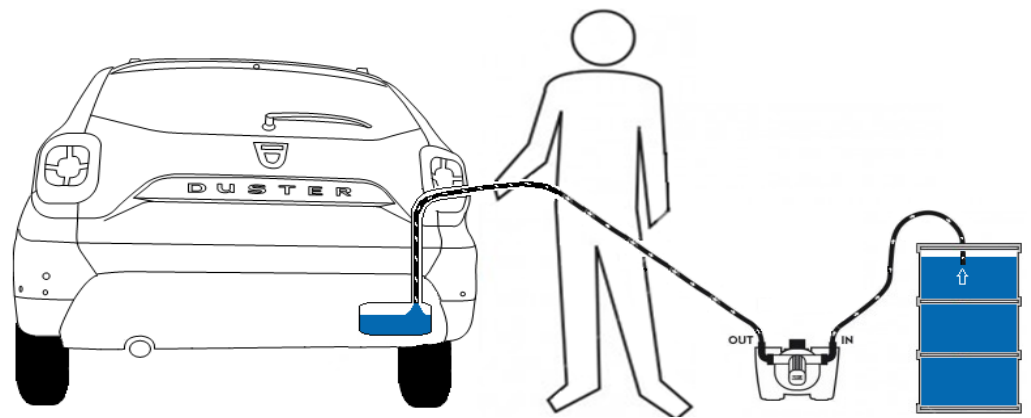

17

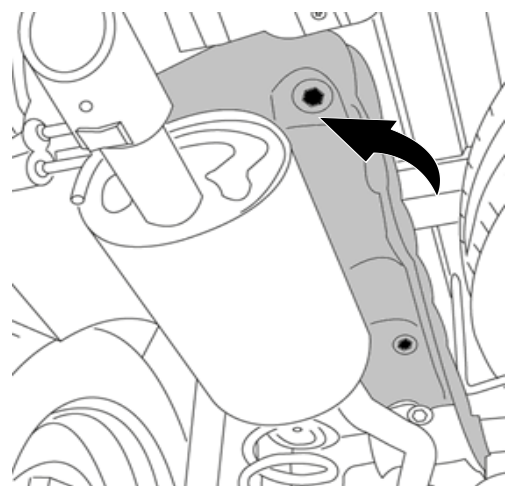
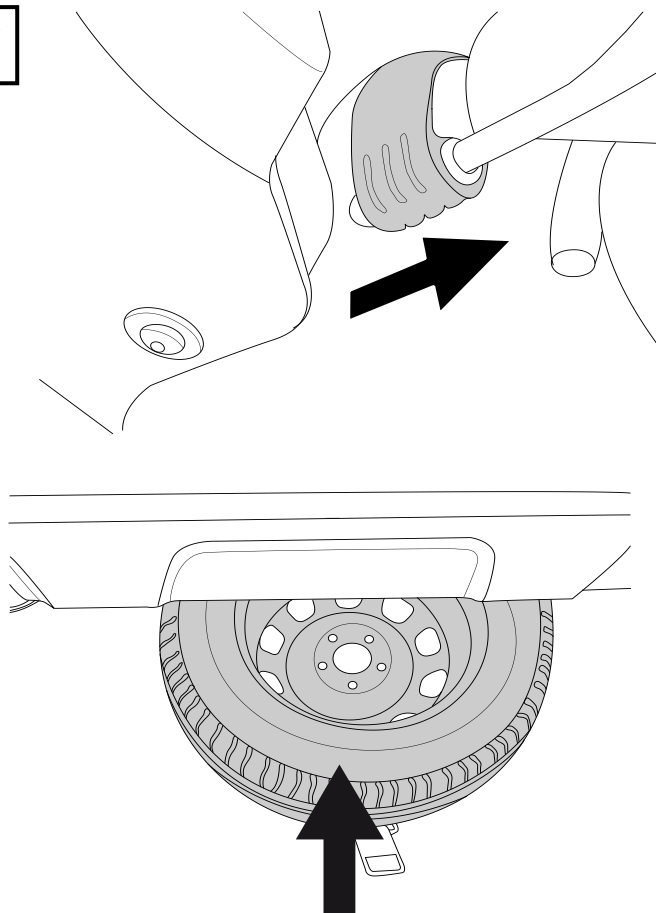

Dispositivo di traino tipo : **316468600001**
Per autoveicolo : **Dacia Duster 2017 >**
Tipo funzionale : **SR*****
HR***

Classe e tipo di attacco : **A50-X**
Omologazione : **e24*R55 01 0445**
Valore D : **8,75 kN**
Carico verticale max. S : **75 kg**
Larghezza rimorchiabile per Caravan e T.A.T.S. : 2,55m vedere CARTA di CIRCOLAZIONE VEICOLO (motrice) + 70cm = ...arrotondare ai 5cm superiore (vedi D.M.28/05/85)
Massa rimorchiabile : vedi carta di circolazione dell'autoveicolo

Per verificare l'idoneità del dispositivo di traino omologato a norma CEE R55, all'installazione sulla vettura su cui si intende procedere al montaggio, compilare la seguente formula (se necessario declassare la massa rimorchiabile) :

$$D = \frac{T \times C}{T + C} \times 0,00981 \leq 8,75 \text{ kN}$$

dove : T = Massa Complessiva Max. della motrice (in kg)
C = Massa Rimorchiabile Max. della motrice (in kg)

DA COMPILARE PER IL COLLAUDO

DICHIARAZIONE DI CORRETTO MONTAGGIO : la sottoscritta Ditta dichiara di aver montato in maniera corretta ed in conformità alle prescrizioni sia del costruttore del veicolo che del costruttore del dispositivo stesso il seguente dispositivo di attacco meccanico :

tipo :
Il dispositivo di attacco sopra indicato è stato installato su autoveicolo
modello :
targa :
Data :

TIMBRO e FIRMA

Si dichiara inoltre di aver informato l'utente del veicolo sull'USO e MANUTENZIONE del dispositivo stesso.