

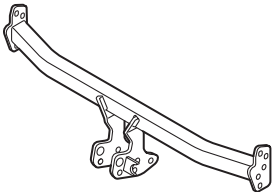

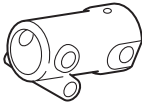

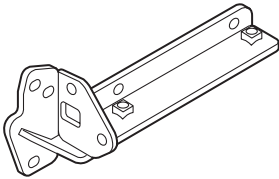

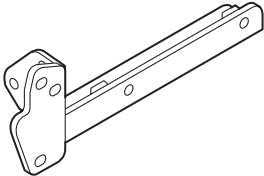

INDEX

Parts List..... 1
 Tools and Supplies Required 2
 Before You Begin
 ○ Symbol Messages..... 3
 ○ Customer Information 3
 Illustration of The Components..... 4
 Installation 5

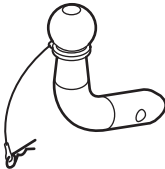
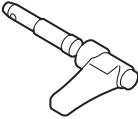
Parts List

<p>Main bar</p> 	<p>Reception tube</p> 	<p>Side stay (right)</p> 
<p>Side stay (left)</p> 	<p>Collars A (36 mm) (2)</p> 	<p>Collars B (21 mm) (2)</p> 
<p>Plates (4)</p> 	<p>Coupling ball</p> 	<p>Eccentric pin</p> 
<p>Hex bolts, 12 x 100 mm (3)</p> 	<p>Hex bolts, 12 x 40 mm (10)</p> 	<p>Hex bolts, 8 x 25 mm (4)</p> 

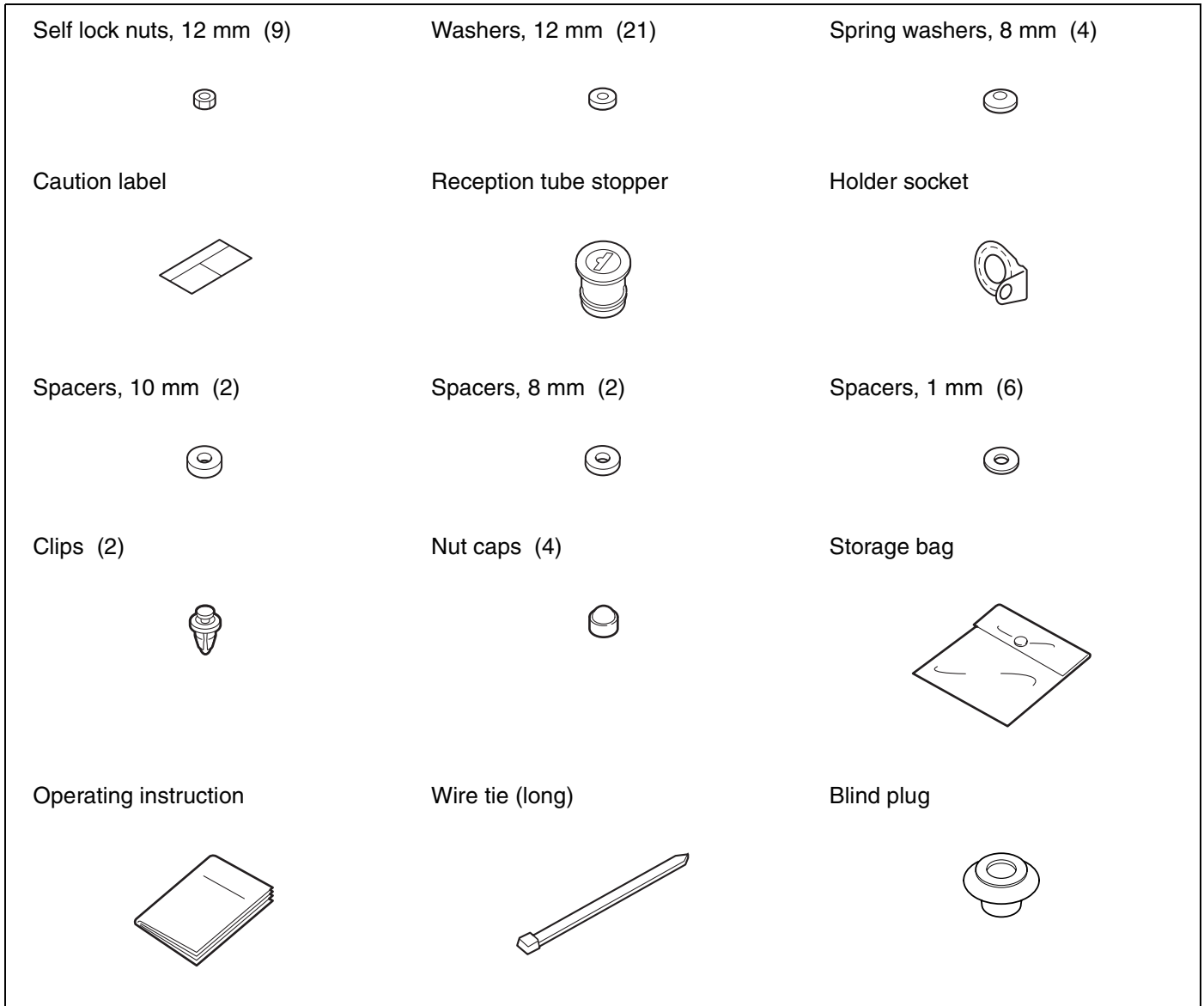

Tools and Supplies Required

- Ratchet
- 12 mm, 13 mm, 16 mm, 18 mm Combination wrenches
- Utility knife
- 10 mm, 12 mm, 13 mm, 16 mm, 18 mm Sockets
- Flat-tip screwdriver
- Torque wrench
- Blanket

Before You Begin

Symbol Messages

We have provided the safety messages preceded by the following safety symbol and one of the signal words of DANGER, WARNING or CAUTION in this manual to warn you about the possible hazards to the operator and the other people and how to avoid these hazards.

Read these safety messages carefully.

DANGER

- You will be killed or seriously hurt if you do not follow the instructions.

WARNING

- You can be killed or seriously hurt if you do not follow the instructions.

CAUTION

- You can be hurt if you do not follow the instructions.

Customer Information

- Use two people to install this trailer hitch.
- Be extremely careful not to damage the rear bumper and body paint finish when removing and installing the rear bumper.
- Before removing parts, note their locations so that they can be reinstalled in their original places properly.

Illustration of The Components

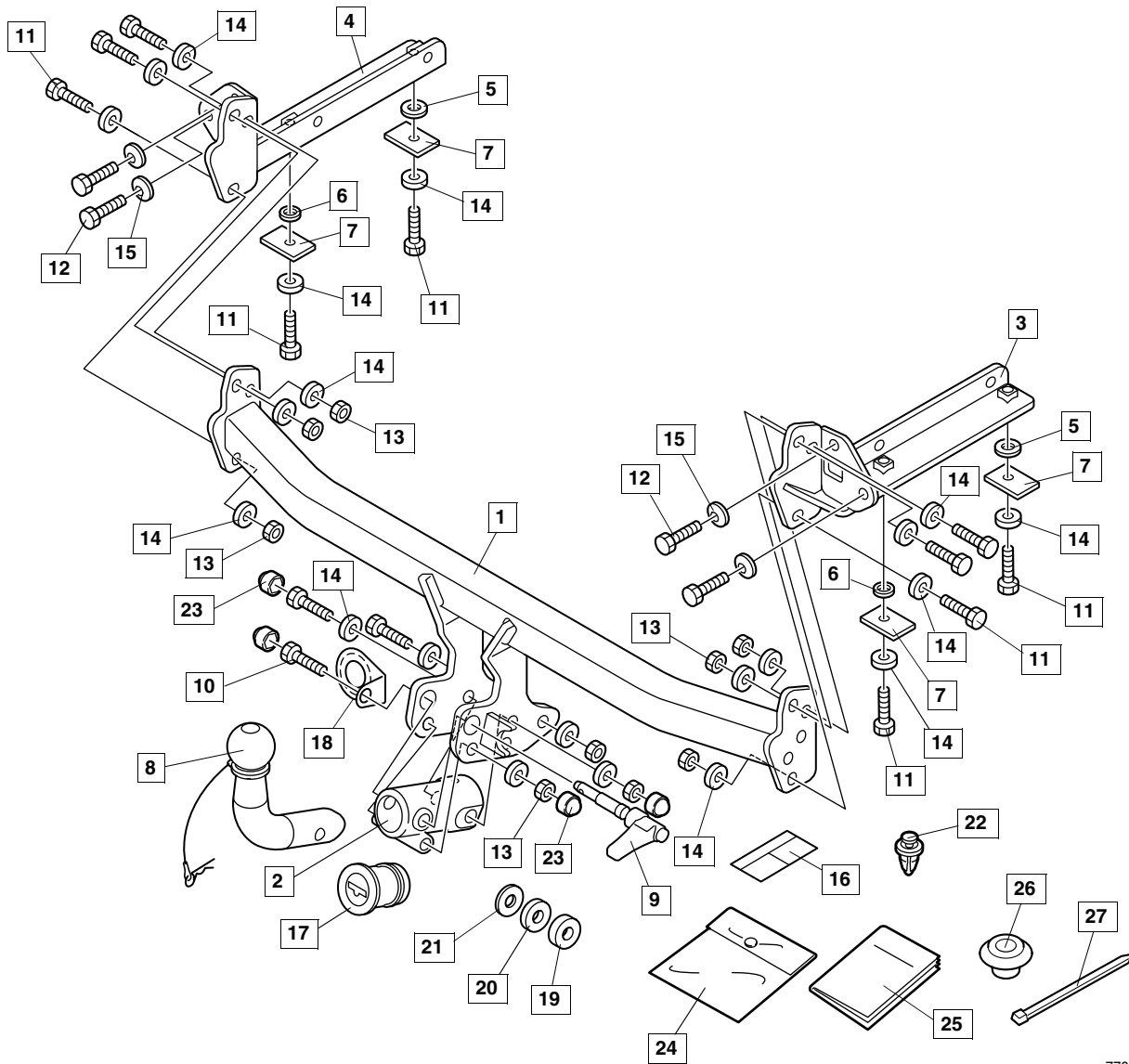

770501AT

NO.	Part Name	NO.	Part Name	NO.	Part Name
1	Main bar	2	Reception tube	3	Side stay (right)
4	Side stay (left)	5	Collar A (36 mm)	6	Collar B (21 mm)
7	Plate	8	Coupling ball	9	Eccentric pin
10	Hex bolt, 12 x 100 mm	11	Hex bolt, 12 x 40 mm	12	Hex bolt, 8 x 25 mm
13	Self lock nut, 12 mm	14	Washer, 12 mm	15	Spring washer, 8 mm
16	Caution label	17	Reception tube stopper	18	Holder socket
19	Spacer, 10 mm	20	Spacer, 8 mm	21	Spacer, 1 mm
22	Clip	23	Nut cap	24	Storage bag
25	Operating instruction	26	Blind plug	27	Wire tie (long)

Installation

1. Open the tailgate.
2. Remove the clip (A) and screw from the rear fender arch molding. Release the seven retaining clips and the two retaining clips (large) of the rear fender arch molding. Slide the rear fender arch molding outward.
 - Insert the shop towel between the rear fender arch molding and the rear fender.
3. Repeat the procedure on the other side.

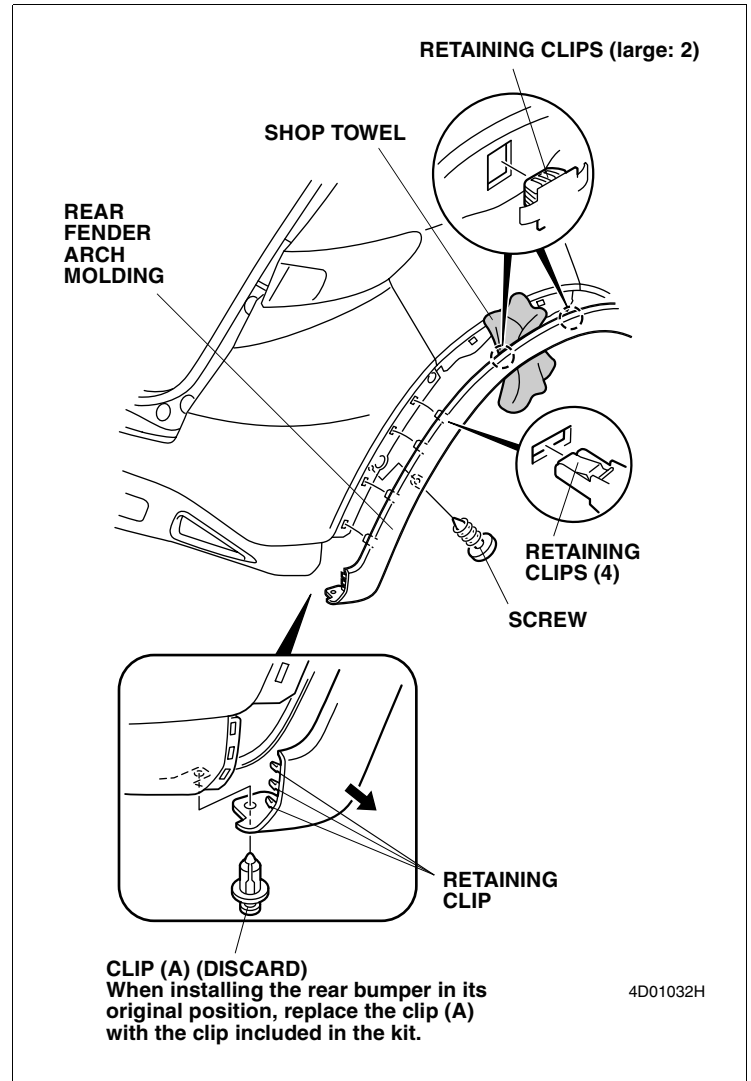

4. Remove the two self-tapping screws and the four clips.
5. Release the four bumper caps and four bolts, and remove the rear bumper by spreading it out to the right and left sides.
 - Have an assistant help you when removing and installing the rear bumper.
 - Put the rear bumper on a blanket not to damage it.

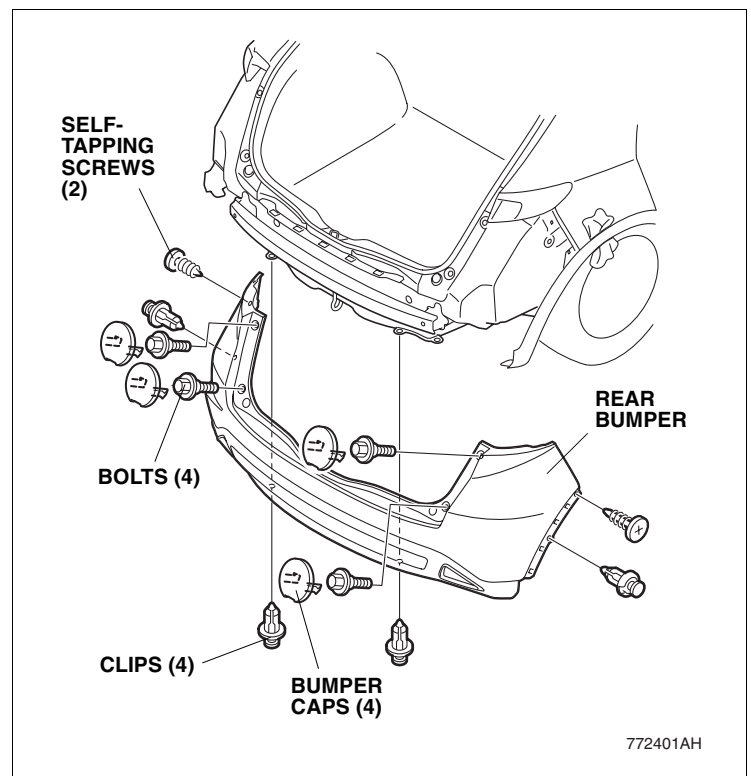

<With rear parking sensor>

- Disconnect the rear parking sensor connector.

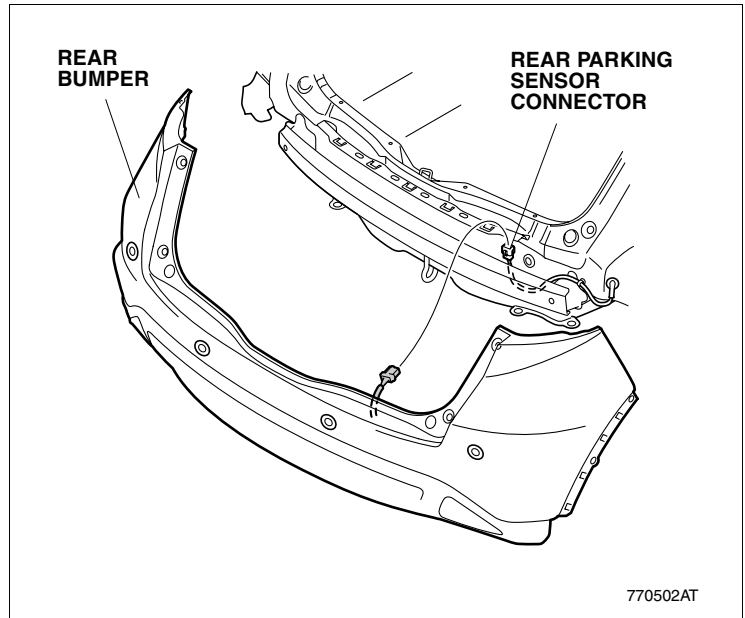

6. Remove the six bolts from the rear bumper beam.
7. Release the retaining tab by sliding the rear bumper beam upward. Remove the rear bumper beam.

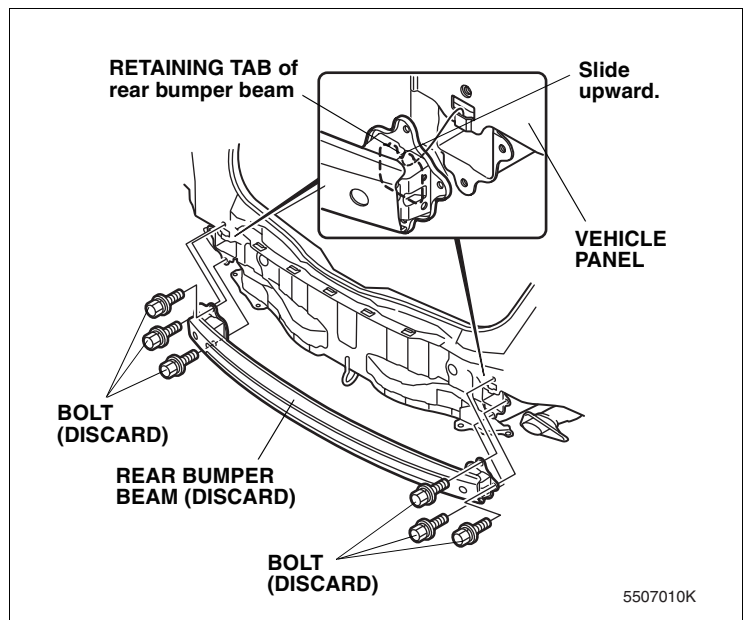

<With rear parking sensor>

- Release the rear parking sensor harness clip.
- Attach the blind plug as shown.

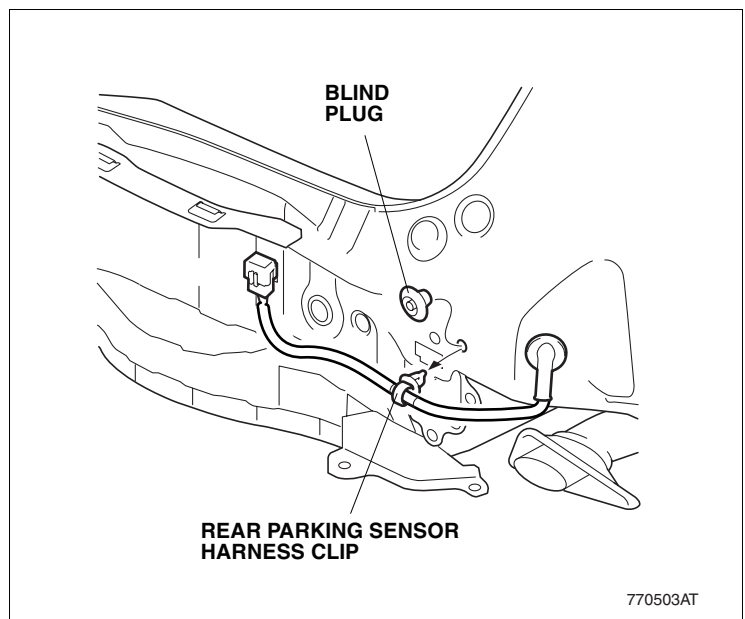

8. Insert the side stay into the hole where you removed the rear bumper beam and loosely tighten the four 8 x 25 mm hex bolts and the four 8 mm spring washers.
 - Do not interchange the right and left side stays.

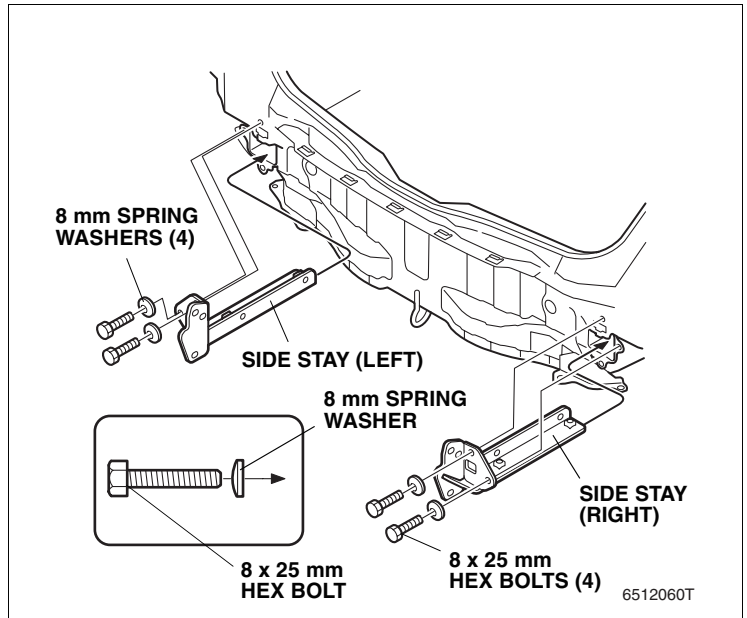

9. Loosely install the side stay (right) on the vehicle's side frame using two 12 x 40 mm bolts, collar A (36 mm), collar B (21 mm), two plates and two 12 mm washers.
 - Install the collar A (36 mm) and B (21 mm) with care not to interchange them.
 - Note the installation direction of the plates.
10. Repeat the procedure on the other side.

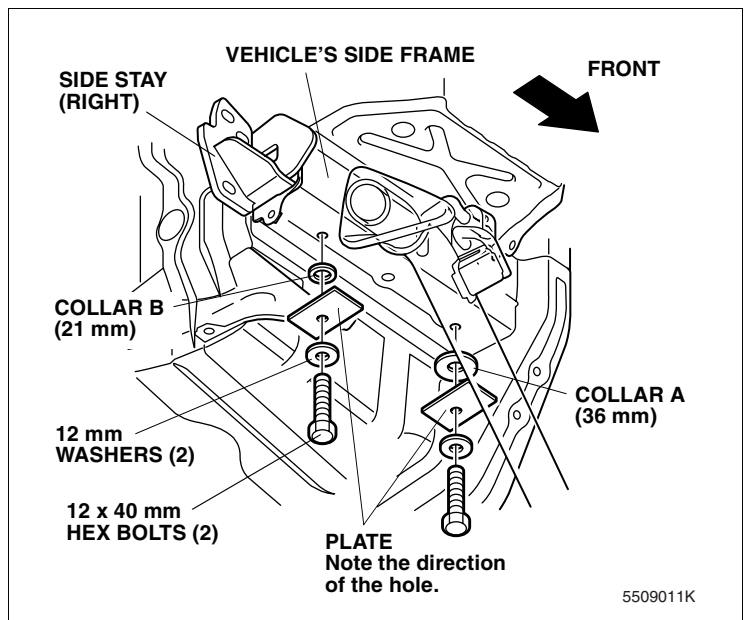

11. Loosely install the main bar on the side stay with six 12 x 40 mm hex bolts, six 12 mm self-lock nuts and twelve 12 mm washers.
- Note the bolt direction.
 - Align the coupling ball installation part of the main bar with the vehicle's tie-down hook.

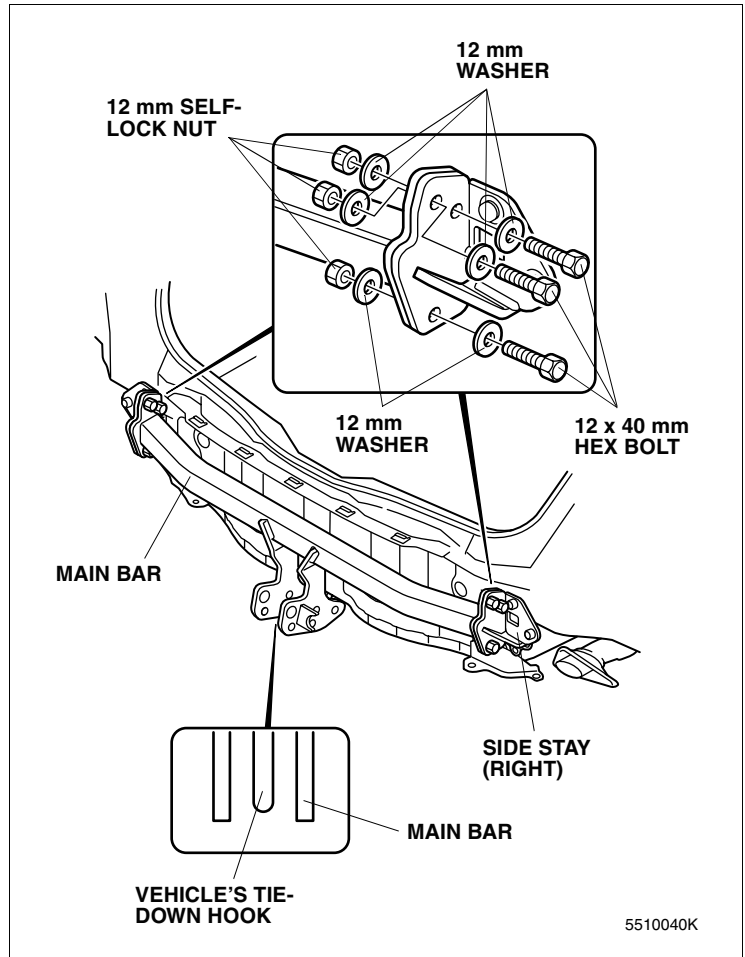

12. Install the reception tube and holder socket on the main bar plate with two 12 x 100 mm hex bolts, three 12 mm washers and two 12 mm self-lock nuts.

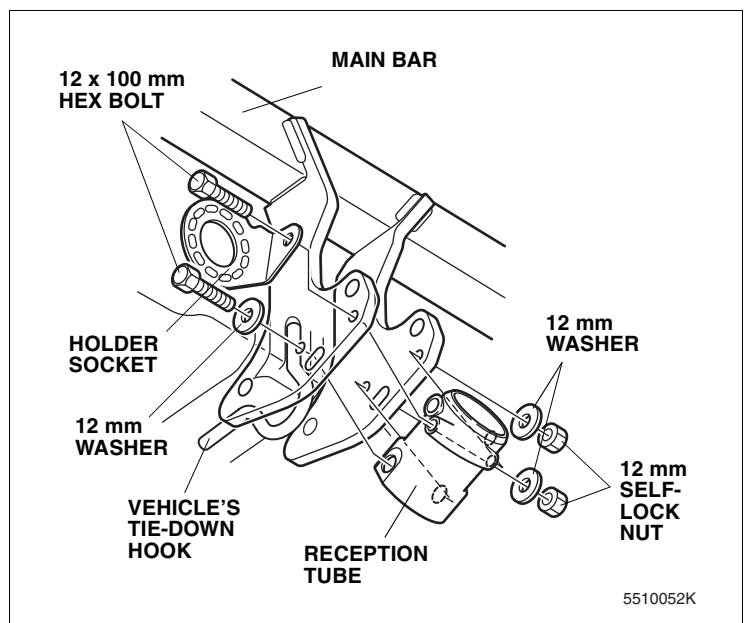

13. Tighten the loosely tightened bolts to the specified torque in the order of 1, 2, 3, and 4.
 - Loosely Install the main bar on the vehicle's tie-down hook with a 12 x 100 mm hex bolt, two 12 mm washers, spacers (necessary quantity) and a 12 mm self-lock nut.
 - Note the bolt installation direction.
 - Use the necessary amount of the spacers to make the thickness adequate for the vehicle. Combine the spacers and adjust the thickness so there is no free play in the spacers.
 - Remove the bolts that tighten the side stay once if they hinder you from tightening the bolts to secure the main bar. Secure the side stay after securing the main bar.
14. Install the four nut caps on the two hex bolts and two self lock nuts as shown.

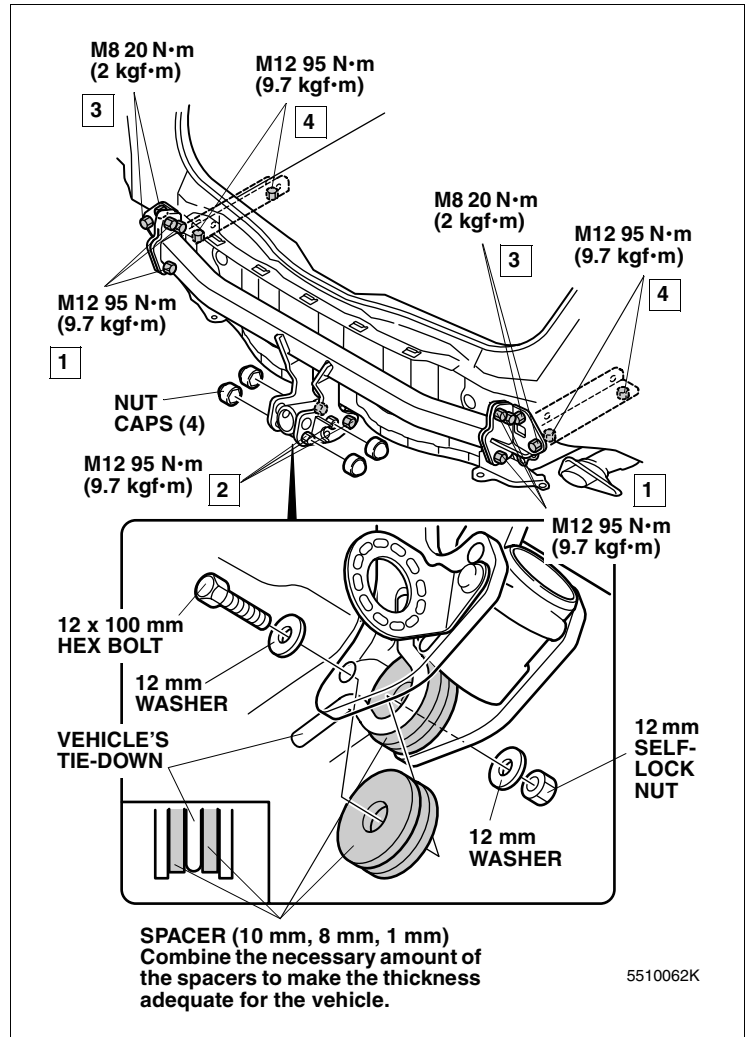

<With rear parking sensor>

- Secure the rear parking sensor harness with a wire tie (long) as shown.

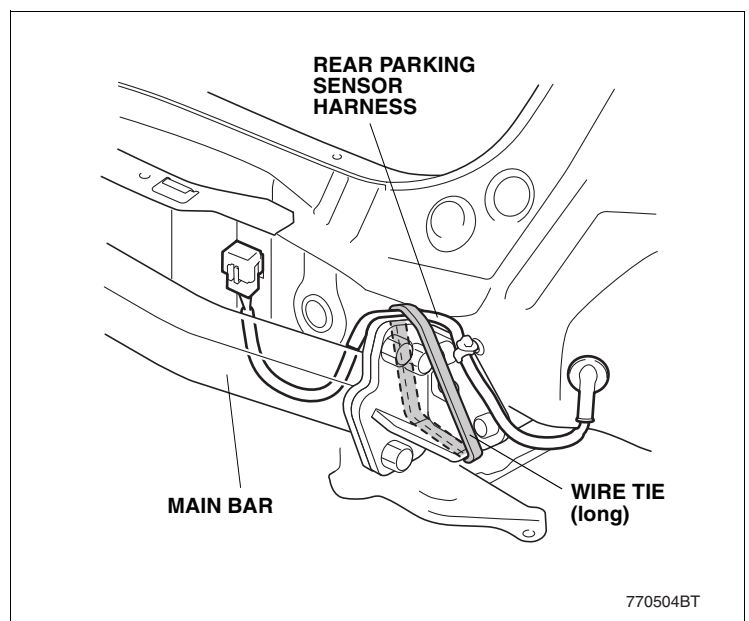

15. Using a utility knife, cut out the rear bumper along the marks on the inner side of the rear bumper.

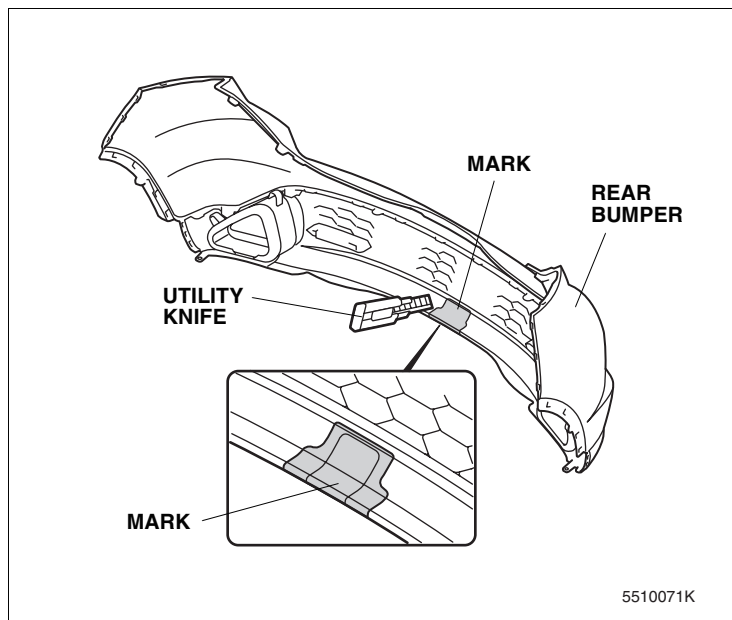

16. Install the rear bumper in its original position.
- When installing the rear bumper in its original position, use the clip included in the kit.

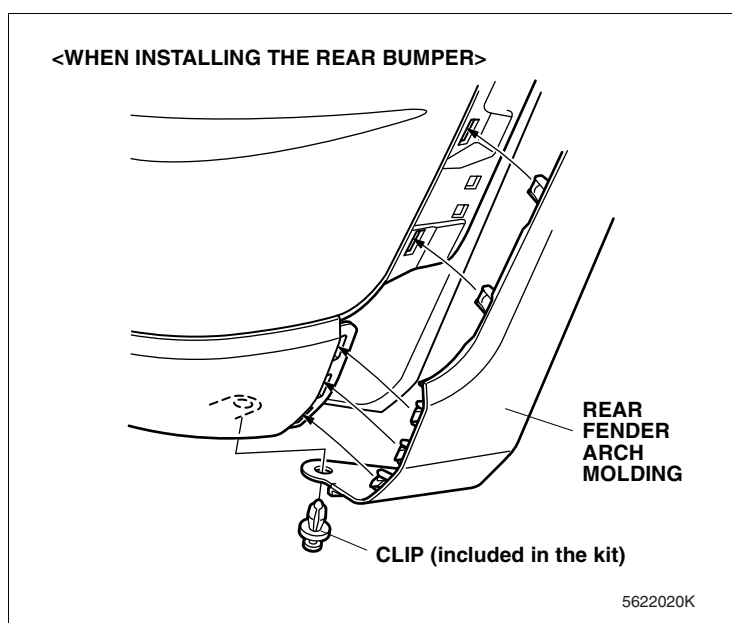

17. Insert the coupling ball into the reception tube.
18. Insert the eccentric pin into the main bar panel.
19. Turn the eccentric pin toward the mark on the trailer hitch main bar and hold it in the position. Secure the eccentric pin by inserting the pin of the coupling ball into the hole at the end of the eccentric pin.

⚠ CAUTION

- After about 1,000 km (620 miles) of use, retighten bolts and nut to the specified torque.

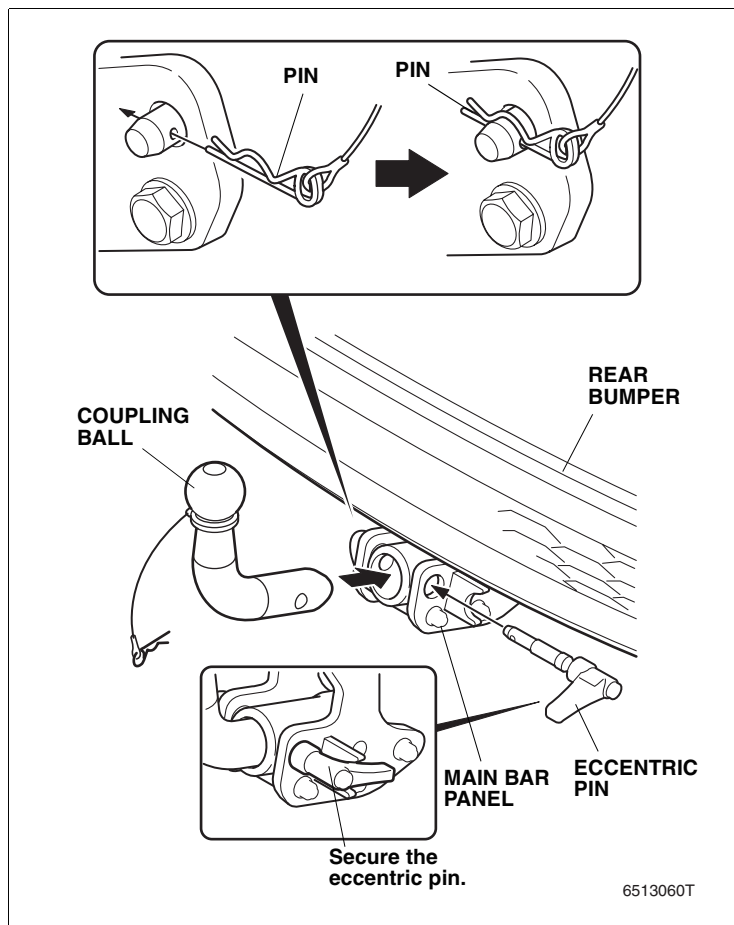

Towbar	Car type	Type de véhicule	Fahrzeugtyp	Autotype	Tipo vettura	Tipo de vehículo	Tipo de veículo	Biltyp
Crochet d'attelage Anhängavorrichtung Trekhaak Gancio di traino Barra de remolque Barra de reboque Dragkroksanordning	Manufacturer Fabricant	Name Nom	Variation Exécution	Type Type	European Homologation no. N° européen d'homologation	European Homologation no. N° européen d'homologation	European Homologation no. N° européen d'homologation	European Homologation no. N° européen d'homologation
	Hersteller Producent	Handelsbez. Benaming	Ausführung Uitvoering	Fahrzeugtyp Type	EG Typgenehmigungsnr. Europees Homologatienummer	EG Typgenehmigungsnr. Europees Homologatienummer	EG Typgenehmigungsnr. Europees Homologatienummer	EG Typgenehmigungsnr. Europees Homologatienummer
	Produttore Fabricante	Nome Nombre	Versione Versión	Tipo Tipo	Omologazione Europea N° Homologación europea número	Omologazione Europea N° Homologación europea número	Omologação Europeia n.º Homologação Europeia n.º	Omologação Europeia n.º Homologação Europeia n.º
	Tillverkare	Modelo Namn	Versão Utförande	Código Typ	EU typgodkänningsnr	EU typgodkänningsnr	EU typgodkänningsnr	EU typgodkänningsnr
HONDA P-NO 08L92-SMG-601 WESTFALIA P-NO 338044	Honda	CIVIC 5D	1.4 1.8 2.2	FK1 FK2 FK3	e11*2001/116*0255*.. e11*2001/116*0256*.. e11*2001/116*0257*..	e11*2001/116*0255*.. e11*2001/116*0256*.. e11*2001/116*0257*..	e11*2001/116*0255*.. e11*2001/116*0256*.. e11*2001/116*0257*..	e11*2001/116*0255*.. e11*2001/116*0256*.. e11*2001/116*0257*..

Approval number Numéro de type - approbation Prüfungsnummer Typegoedkeuringsnummer Numero di approvazione Número de aprobación Número da aprovação Godkänningsnummer	e13*94/20*1902*00	Marked number Numéro de marque Markierung Typenschild Markering typeplaatje Italiano Número marcado Número gravado Markeringsnummer	00-1902
---	--------------------------	--	----------------

Max. permissible weight towing vehicle Poids max. autorisé du véhicule trainant Zul. Kfz.-Gesamtgewicht Max. toegestaan voertuiggewicht Peso max. consentito del veicolo trainante Peso máximo autorizado del vehículo remolcador Peso máx. permitido do veículo que reboca Max tillåten total fordonsvikt	1900 kg	Max. trailer weight of the towbar Poids max. de remorquage du crochet d'attelage Max. Anhängelast der Anhängavorrichtung Max. massa a.h.w. van de trekhaak Peso max. trainabile del gancio di traino Peso máximo de arrastre de la barra de remolque Peso máx. reboçável pelo engate de reboque Max släpvikt för dragkroken	1500 kg
---	----------------	--	----------------

Max. nose weight Poids max. vertical Max. Stützlast Max. verticale last Peso max. verticale Peso máximo vertical Peso máx. vertical no engate de reboque Maximal stödlast	75 kg	D value Valeur D D Wert D waarde Valore D Valor D Valor D D-värde	8,8 kN
--	--------------	--	---------------

For these values, please refer to the owner's manual or your car.
Pour connaître ces valeurs, consultez le guide d'utilisation de votre voiture.
Für diese Werte sehen Sie bitte in der Bedienanleitung Ihres Fahrzeuges nach.
Voor deze waarden dient u de gebruikershandleiding van uw auto te raadplegen.
Per questi valori, vi rimandiamo al manuale della vostra auto.
Para estos valores, remítase al manual del propietario de su coche.
Para estes valores, por favor refira-se ao manual do proprietário para o seu carro.
Du hittar dessa värden i bruksanvisningen för din bil.

This tow bar has been tested according to the new EEC 94/20 directions. The tow bar approval number is mentioned on the type label.

L'attelage a été testé suivant la nouvelle directive EEC 94/20. Le numéro d'homologation de l'attelage est noté sur la plaque mentionnant le type.

Diese Anhängzugvorrichtung ist nach der neuen Richtlinie EEC 94/20 geprüft worden. Gemäß dieser Richtlinie entfällt auch die Notwendigkeit, die Homologationsnummer direkt an der Anhängzugvorrichtung zu markieren. Deshalb ist die Prüfnummer der Anhängzugvorrichtung ausschließlich auf dem Typschild vermerkt.

Deze trekhaak is volgens de nieuwe richtlijn EEC 94/20 getest. Het goedkeuringsnummer van de trekhaak staat op het typeplaatje.

Questo gancio di traino è stato collaudato secondo la nuova normativa 94/20/CEE. Il suo numero di approvazione è riportato sulla targhetta del veicolo.

Esta barra de remolque ha sido comprobada según las nuevas directivas EEC 94/20. El número de aprobación de la barra de remolque figura en la etiqueta del tipo.

Esta barra de reboque foi ensaiada de acordo com as novas directivas EEC 94/20. O número da aprovação da barra de reboque está indicado na autocolante.

Denna dragkroksanordning har testats enligt de nya EEC 94/20 direktiven. Dragkrokens godkänningsnummer anges på typskylten.

For cars with automatic transmission a Honda ATF cooler could be required. Consult your dealer.

Pour véhicules avec une transmission automatique un refroidisseur Honda ATF pourrait être requis. Consultez votre concessionnaire.

Für Fahrzeuge mit Automatikgetriebe könnte ein Honda ATF Kühler erforderlich sein. Fragen Sie Ihren Händler.

Voor wagens met automatische transmissie zou een Honda ATF cooler nodig kunnen zijn. Raadpleeg uw dealer.

Per automobili con la trasmissione automatica, potrà essere richiesto un refrigerante Honda ATF. Consultate il vostro concessionario.

Para coches con transmisión automática, es posible que se requiera una unidad de refrigeración Honda ATF. Consulte con su distribuidor.

Para carros com transmissão automática, um arrefecedor Honda ATF poderia ser requerido. Consulte seu revendedor.

För bilar med automatisk växellåda kan en Honda ATF-kylare behövas. Samråd med din återförsäljare.