



Original Zubehör
Genuine Accessories
Accessoires d'Orgine

Fitting instructions

Electrical installation kit

Part number

8E5 055 203 GA

Distributed by Votex GmbH

USA: Distributed by
Volkswagen of America. Inc.
Auburn Hills / Mi.

The right to modify specifications is reserved

Printed in West Germany by
Votex GmbH

Vehicle model: **Audi A4 Saloon, Avant RHD 7-pin**
 Audi A4 Cabriolet RHD 7-pin

11/04 >>

11/05 >>

GB

Includes:

- 1 Cable set, 8-core with pre-assembled socket,
- 1 Trailer connection unit
- 1 Socket housing 7-pin, incl. fitting material
- 1 Flat pin fuse 20 A
- 15 Cable ties 150 mm long
- 2 Cable ties 300 mm long
- 6 Cable ties with plug-in fixing

General procedure:

- Install electrical kit
- Fit socket
- Connect trailer connection unit
- Check operation

Important note

Before starting work read the installation instructions.

Only qualified specialists are allowed to install the electrical installation kit.

Follow guidance in the current repair manual when carrying out installation work on the vehicle.



Caution - disconnect battery

Damage to the vehicle electronics may result in loss of stored electronic data.

Before starting work read out error memory.

► Note

When fitting, pay particular attention to the following points:

- Wiring must not be pinched or damaged.
- All seals must be properly seated.
- The seal for the socket must be positioned on the insulating sleeve and not on the individual wires.
- Route wiring so that it does not chafe against the vehicle or break off.
- Do not route wiring immediately next to the exhaust system.
- When fitting the control unit make sure that moisture cannot penetrate. The cable connection should always point downwards.

The additional warning lamp (C2) for checking the turn signal indicator on the trailer is already factory-fitted and accordingly pre-assembled.

For trailer operation the rear fog light of the towing vehicle is disabled.

A rear fog light must be retrofitted on trailers not already equipped with one.

A socket adapter may only be used in trailer operation. Remove the socket adapter when trailer operation is not in use.

Check the operation of the trailer using a trailer or test equipment with load resistances.

Subject to technical changes!

Installation overview

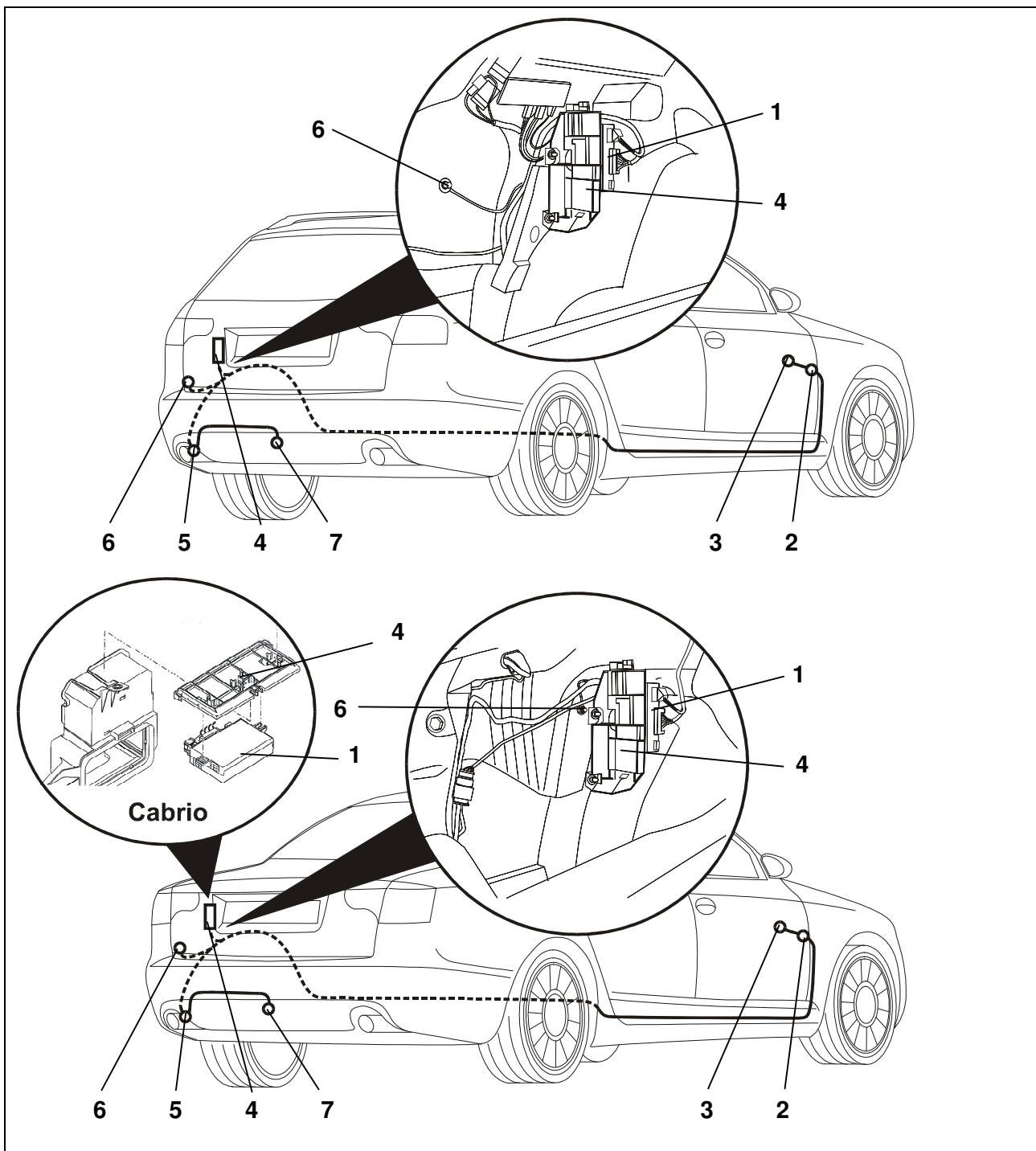

Fig. 1: Installation overview

- | | |
|---------------------------|------------------|
| 1 Trailer connection unit | 5 Cable hole |
| 2 Fuse box | 6 Ground point |
| 3 ILM control unit | 7 Trailer socket |
| 4 Equipment rack | |

Install electrical kit

1. Disconnect battery.
2. Remove the following covers and panelling, as necessary:
 - In the boot
 - Boot floor cover
 - Loading sill cover
 - Left side panel
 - Along the right hand side of the vehicle
 - Side panel rear (Cabrio)
 - Scuff plates, driver's side
 - Right panelling by the steering column
 - Fuse box cover
3. Remove the cover from the 40 mm hole in the floor panel, below the left tail light (Fig. 1/5).

► Note

In vehicles with tyre pressure check: remove the 4-pin plug from the tyre pressure monitoring unit at the back right on the bumper. Unlock the black outer housing on this plug, open the green secondary lock and unclip the three cables. Remove the hole grommet 4B0 971 908 from this cable loom. On the towing hitch cable set, expose the second opening of the hole grommet 4B0 971 908, feed the cable set for the tyre pressure check and seal it correctly. Re-assemble the 4-pin plug in the reverse order.

Chamber 1 = br/bl, chamber 2 = ye/bl, chamber 3 = gn/pu.

4. Route the end of the cable with the 14-pin and 6-pin plugs from outside through the hole to the equipment rack (Fig. 1/4).
5. Insert the rubber grommet in the hole (fig. 1/5).
6. Route the end of the cable set with the socket to the socket mounting plate (fig. 1/7).
7. Secure the socket cable set (in vehicles with a tyre pressure monitoring function, secure the cable set for the tyre pressure monitoring unit as well) between the tail end panel and the towing hitch on the bumper carrier with plug-in fixing cable ties.

Fit socket

8. Push contact insert into the socket housing and slide rubber seal up to the socket.
9. Secure the socket to the mounting plate with the screws provided (Fig. 1/7), torque setting: max. 2.0 Nm.. If necessary shorten screws.

Connect trailer connection unit

► Note

If the equipment rack 8E0 907 297 B (Saloon & Avant) or the bracket 8E0 907 297 (Cabriolet) for the trailer control unit is not present in the vehicle, this must be ordered with two nuts N901 326 02 (only Saloon and Avant) from VW Kassel.

10. Fit the trailer connection unit into the equipment rack on the rear, left-hand side of the vehicle facing the direction of travel (Fig. 1/4).
11. Plug and lock in the 14-way and 6-way plug housings of the 8-core cable set in the sockets provided on the trailer connection unit (Fig. 1/1).
12. Connect the brown wire with eyelet to the vehicle ground point (Fig. 1/6) by the equipment rack.
13. Route the cable set over the left wheel housing up to the rear bench seat, then across from left to right and along the existing cable looms / cable ducts on the driver's side up to the ILM control unit for the vehicle electrical system in the driver's footwell (Fig. 1/3).
14. Disconnect the grey 32-pin plug from the ILM control unit (Fig. 1/3) and open the purple catch. Release the following wires and insert into the black 3-pin socket housing on the cable set:
 - Orange/brown wire from chamber 12 into chamber 1.
 - Orange/green wire from chamber 13 into chamber 2.
 - Black/red wire from chamber 15 into chamber 3.
15. Insert the orange/green, orange/brown and black/red wires from the 8-core cable set according to colour into the freed chambers 12, 13 and 15 of the 32-pin plug.
16. Make sure that no more than 30 mm of the orange/brown and orange/green wires are untwisted.
17. Close catches and reconnect plug to the ILM control unit (Fig. 1/3).
18. Plug the open 3-pin housings together.
19. Remove the black cover on the fuse box (Fig. 1/2) and open the purple catch.
20. Remove 10A fuse from pos.5, release the black/red, fuse-protected wire from chamber 5 and insert into the 1-pin housing on the cable set.
21. Insert the black/red wire from the 8-core cable set into chamber 5 on the fuse box and replace the 10A fuse.
22. Plug the 1-pin housings together.
23. Insert the single 2.5mm² red/black wire into chamber 27 on the fuse box (Fig. 1/2).
24. Close the purple catch on the fuse box and replace the black cover.
25. Insert the 20A fuse provided in fuse position 27.

Check operation

26. Re-connect battery.
27. Match the vehicle code in the following control units via selected diagnostics by coding "Anhängerkupplung verbaut" (towing hitch installed):
 - 01 Engine electrical system (varies from engine to engine, visible in selected diagnostics)
 - 09 Electronic central electrics
 - 76 Park distance control APS
28. Change the adaption of the dash panel insert via the selected diagnostics by coding "Anhängerkupplung verbaut" (towing hitch installed):
 - 17 Dash panel insert Adapt J285 data bus convenience

► Note

Changing the code also affects the cooling system control unit in the vehicle. Depending on the previous vehicle fitting, you may therefore have to adapt the vehicle's cooling system when retrofitting the towing hitch. You will find more information on this in the Service-Net.

29. Check the operation of the trailer using suitable test equipment (with load resistances) or with a trailer.
30. Check the entries in the error log, and delete them if necessary.
31. Using the Software Versions Management (SVM) system of the selected diagnostics, perform an on-line document retrieval for the vehicle with the action number 050200.
32. Secure all cables with cable ties.
33. Re-fit all disassembled parts.

Socket allocation

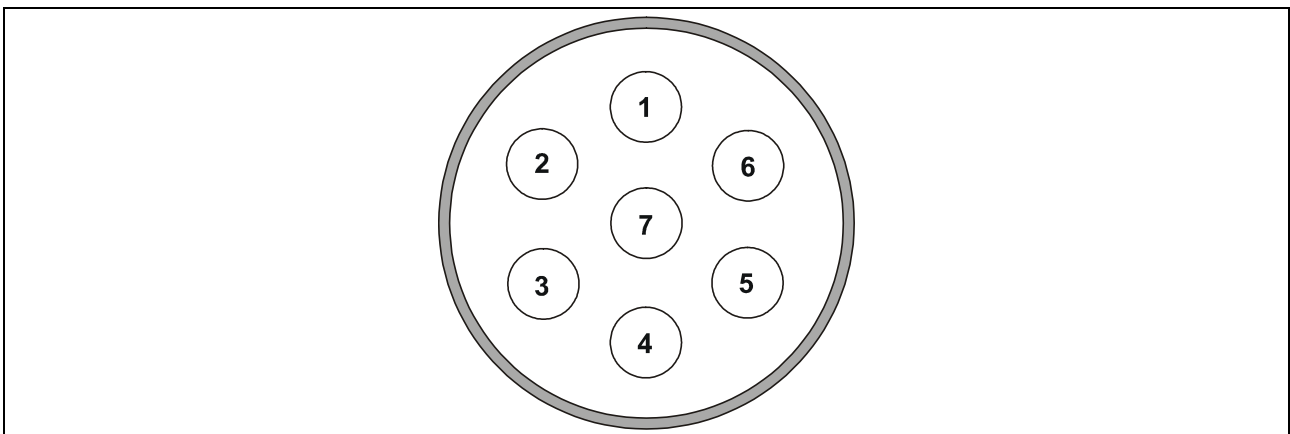

Contact	Circuit	Cable colour
1	Turn signal indicator, left	black/white
2	Rear fog light	grey/blue
3	Ground (Circuit 1-7)	brown
4	Turn signal indicator, right	black/green
5	Tail light, right	grey/red
6	Brake light	black/red
7	Tail light, left	grey/black